

Exclusive Pyramidal Stem Seal Design

1. **PYRAMIDAL MACHINED STEM WITH STEM SEAL** This is the first stage of defense against leakage. The 45 degree slope of the stem accompanied by the shape of the seal effectively blocks any leak path from forming during rotation. The wedging action of this portion of the stem is far superior to flat stem designs when it comes to effective wear compensation..
2. **SECONDARY O-RING BEARING SEAL** Second Stage of sealing also aids in reducing side loading of packing.
3. **V-RING PACKING** Third sealing stage. Triple layers of V-Ring Chevron packing expands side ways as it is compressed and pressurized blocking all air pockets.
4. **LOCK SADDLE** Stabilizes the entire stem nut to keep it from loosening.
5. **STEM NUT** Compresses the entire stem system to ensure leak free operation.
6. **BELLEVILLE WASHER** Releases stored compressive energy for automatic compensation of seals due to seal wear and fluctuation of temperature and pressure.
7. **GLAND** Made of stainless steel. Equally compresses the force on the packing and the seal.
8. **ANTI-STATIC DEVICE**

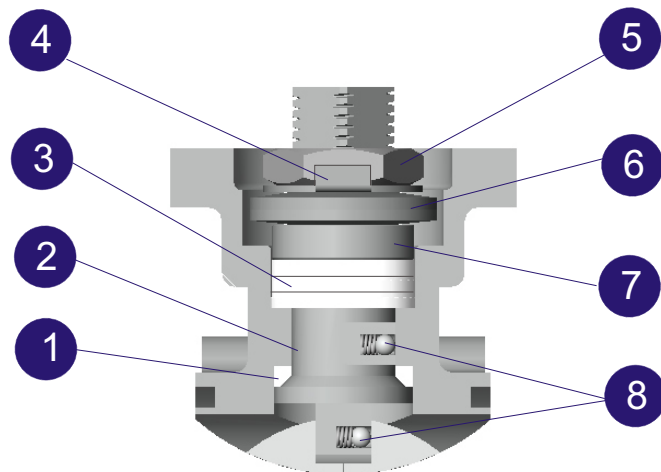

Optional Design For Elevated
Temperatures and Fire Safe
Valves

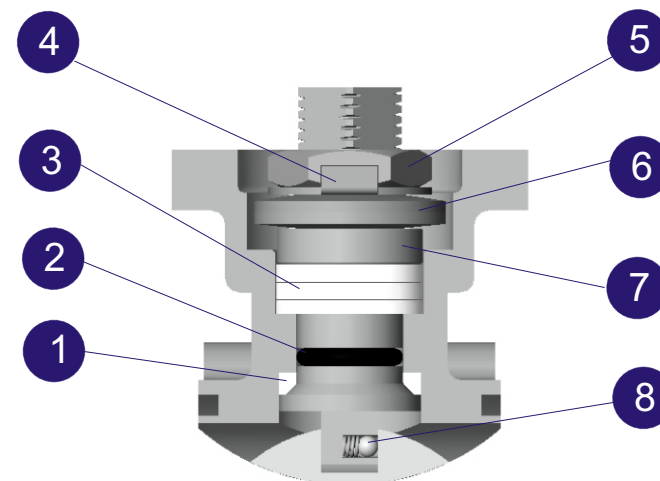

Standard Design