

Series 50 Stainless Steel Ball Valve

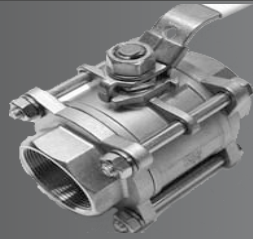

1000 WOG - Full Port
NPT, Socket Weld & Butt Weld Ends

Specifications:

- Three Piece
- End Type: NPT, Socket Weld & Butt Weld
- Pressure rating: 1000 WOG
- Temperature: -20°F to 450°F
- Handle with Locking Device

Dimensions (in.)

SIZE	A	B	d	L	WEIGHT (lbs.)
1/4"	1.97	1.89	0.47	4.06	0.28
3/8"	1.97	1.89	0.47	4.06	0.27
1/2"	2.36	2.05	0.59	4.06	0.44
3/4"	2.76	2.40	0.79	4.84	0.61
1"	3.15	2.56	0.98	4.84	0.82
1-1/4"	3.66	3.11	1.26	6.02	1.47
1-1/2"	3.94	3.27	1.50	6.02	1.80
2"	4.92	3.82	1.97	7.28	3.22
2-1/2"	6.22	5.31	2.52	9.57	6.26
3"	7.05	5.66	2.99	9.57	9.22
4"	8.78	6.77	3.70	12.40	19.59

Pressure Temperature Ratings

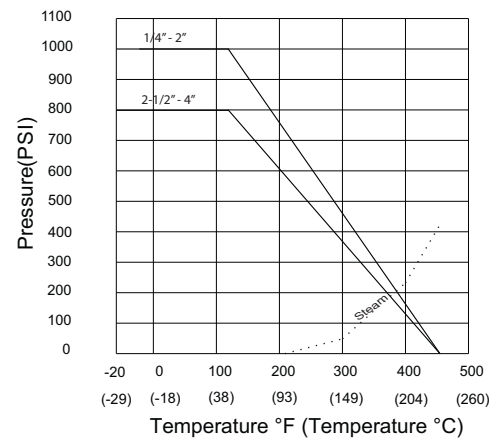

Materials List

NO	PART NAME	MATERIAL	NO. PCS.
1	BODY	316SS	1
2	CAP	316SS	2
3	BALL	316SS	1
4	BALL SEAT	PTFE	2
5	JOINT GASKET	PTFE	2
6	THRUST WASHER	PTFE	1
7	STEM PACKING	PTFE	1
8	GLAND NUT	304SS	1
9	SPRING WASHER	304SS	1
10	NUT	304SS	1
11	STEM	316SS	1
12	HANDLE	304SS	1
13	HANDLE COVER	PLASTIC	1
14	STEM NUT	304SS	4
15	SPRING WASHER	304SS	4
16	BOLT	304SS	4
17	LOCKING PLATE	304SS	1

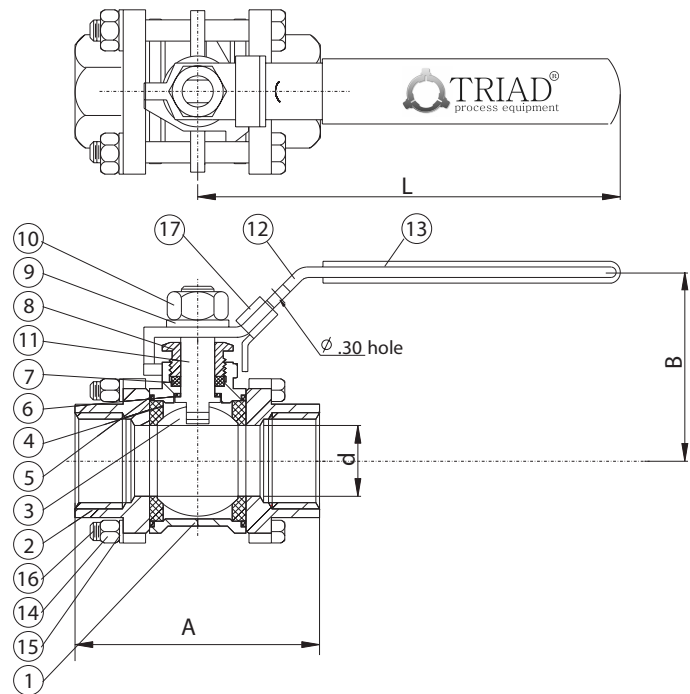

Copyright 2007, Triad Process Equipment® Triad and Triad Process Equipment are registered trademarks. We reserve the right to make technical and or dimensional changes without prior notice.