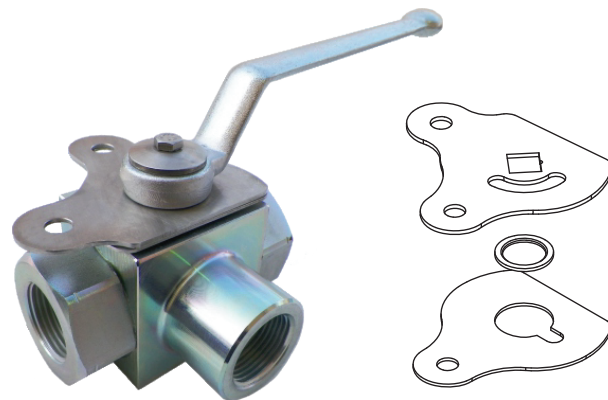
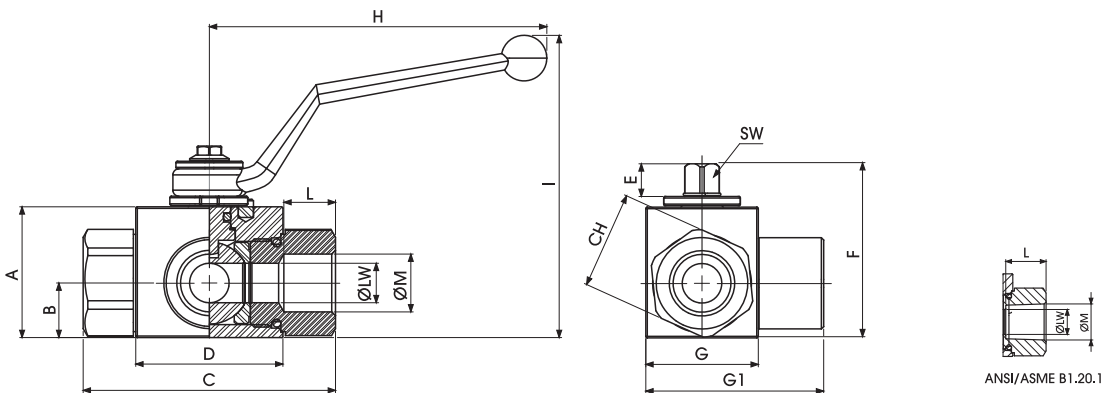

**TRIAD SERIES XHP3W BALL VALVES**  
**3 - WAY HIGH PRESSURE**

**Specifications:**

- Diverting L port configuration
- End Type: NPT
- Pressure rating:  
5802 PSI 1/8" to 3/8"  
5076 PSI 1/2" to 1"
- Temperature: -4°F to 212°F (Carbon Steel)  
-76°F to 446°F (Stainless Steel)
- NPT thread standard
- Optional DIN, SAE and BSP threads available

**Locking Kits available upon request**

**Dimensions**

SIZE	A	B	C	D	E	F	G	G1	H	I	L	ØM	CH	SW	ØLW	LBS.
1/8"	1.38	0.57	2.80	1.67	0.43	1.93	1.18	1.91	4.33	3.60	0.43	1/8	0.94	0.35	0.16	1
1/4"	1.38	0.57	2.80	1.67	0.43	1.93	1.18	1.91	4.33	3.60	0.67	1/4	0.94	0.35	0.24	1
1/2"	1.69	0.71	3.27	1.91	0.43	2.24	1.46	2.30	4.33	3.92	0.83	1/2	1.26	0.35	0.51	2
3/4"	2.24	0.92	3.74	2.46	0.55	2.89	1.93	2.95	7.09	4.19	0.83	3/4	1.61	0.55	0.79	3
1"	2.56	1.16	4.41	2.62	0.55	3.29	2.17	3.50	7.09	4.59	0.94	1	1.97	0.55	0.98	5

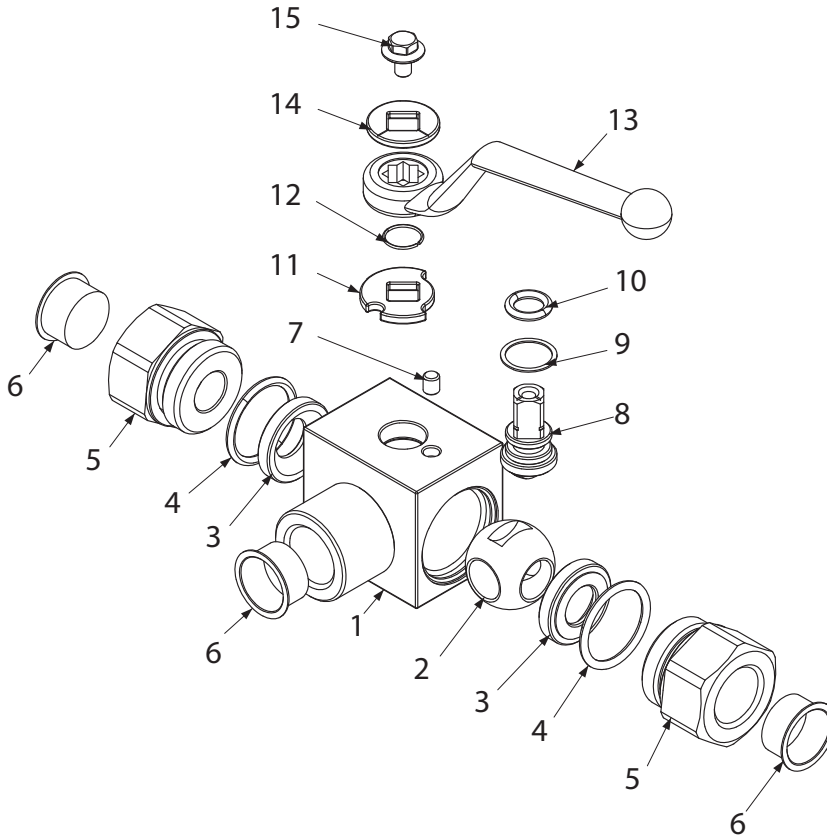
**TRIAD SERIES XHP3W BALL VALVES**  
**3 - WAY HIGH PRESSURE**  
**MATERIAL LIST**



**MATERIAL LIST**

NO.	PART NAME	MATERIAL		NO. PCS.
		CS	SS	
1	BODY	CS	SS	1
2	BALL	CS	SS	1
3	BALL SEAT		POM	2
4	ADAPTER O-RING		NBR	2
5	ADAPTER	CS	SS	2
6	CAPS		PVC	3
7	STOP	CS	SS	1
8	STEM	CS	SS	1
9	STEM RING		POM	1
10	STEM O-RING		NBR	1
11	WASHER	CS	SS	1
12	SNAP RING		SS	1
13	HANDLE		ZINC	1
14	WASHER	CS	SS	1
15	SCREW		DIN 6921 8.8	1

**PRESSURE TEMPERATURE RATINGS**

