

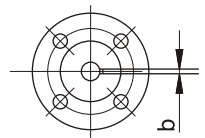

GENERAL DATA SHEET BUTTERFLY VALVE 14" – 40" SERIES 700 – WAFER TYPE STYLE 751

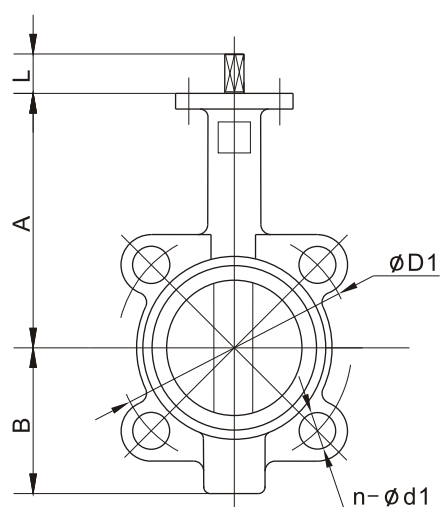

ROUND WITH KEY
FOR SIZES 28" THROUGH 40"

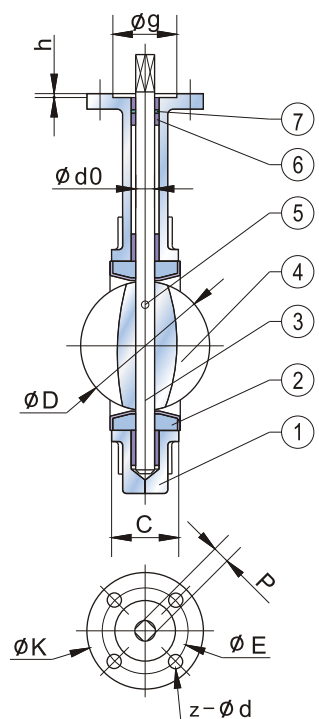

DIAGONAL SQUARE HEAD
FOR SIZES 14" THROUGH 24"

STANDARD MATERIALS OF MAIN PARTS

ITEM	PART NAME	MATERIAL
1	Body	Cast Iron, Ductile Iron, Carbon Steel, Stainless Steel
2	Seat	NBR, PTFE, EPDM, Viton, Neoprene, Hypalon, Silicon
3	Shaft	Stainless Steel 410, 17-4PH, 316
4	Disc	Ductile Iron+Ni, CF8, CF8M, Bronze
5	Pin	Stainless Steel
6	Bushing	PTFE, Bronze
7	O Ring	NBR, EPDM

DIMENSIONS AND WEIGHTS

SIZE		A	B	C	D	L	d0	P	H	UPPER FLANGE				ANSI 150		DIN PN10/16		Weight (lbs)	
in	DN									K	E	z-d	g	h	D1	n-d1	*D1		*n-d1
14	350	14.49	10.51	3.01	13.12	1.77	1.24	0.87	1.06	5.51	F10	4-.47	2.76	0.14	18.74	12-1.14	460-470	16-23/27	91.1
16	400	15.75	12.17	3.41	15.34	2.02	1.31	1.06	1.06	7.76	F14	4-.71	3.94	0.16	21.26	16-1.14	515/525	16-27/30	134.5
18	450	16.61	12.91	4.16	17.34	2.02	1.50	1.06	1.06	7.76	F14	4-.71	3.94	0.16	22.76	16-1.26	565/585	20-27/30	174.2
20	500	18.90	14.21	5.19	19.35	2.53	1.62	1.42	1.26	7.76	F14	4-.71	3.94	0.16	25.00	20-1.26	620/650	20-27/33	282.2
24	600	22.13	18.07	5.98	23.33	2.76	1.99	1.42	1.42	10.87	F16	4-.91	5.12	0.20	29.51	20-1.38	725/770	20-30/36	414.5
28	700	24.57	20.47	6.42	27.36	2.60	2.17	-	-	11.81	F25	8-.71	7.87	0.22	34.00	28-1.38	840	24-30/36	626.1
30	750	25.98	21.22	6.50	29.30	2.60	2.17	-	-	11.81	F25	8-.71	7.87	0.22	36.00	28-1.38	-	-	723.1
32	800	26.46	23.27	7.40	31.29	2.60	2.17	-	-	11.81	F25	8-.71	7.87	0.22	38.50	28-1.61	950	24-33/39	811.3
36	900	28.35	25.83	7.99	34.04	4.65	2.95	-	-	11.81	F25	8-.71	7.87	0.22	42.76	32-1.61	1050	28-33/39	1571.9
40	1000	31.50	28.39	8.50	37.99	5.59	3.35	-	-	11.81	F25	8-.71	7.87	0.22	47.24	36-1.61	1160/1170	28-36/42	1904.8

* - mm

Triad Process Equipment 4922 Technical Dr. Milford, MI 48381
248.685.9938 www.triadprocess.com
Copyright 2005, Triad Process Equipment
Triad and Triad Process Equipment are registered trademarks.
We reserve the right to make technical and or dimensional changes without prior notice.