



SERIES 33D BRASS

3-WAY DIRECT MOUNT BALL VALVE

DIRECT MOUNT - NPT ENDS



Specifications:

- Three Way
- End Type: NPT
- Pressure rating: 400
- Temperature: to 344°F
- Blow-out proof stem design
- ISO 5211 Mounting Pad

Order Information:

T Port: 33DT-52011
L Port: 33DL-52011

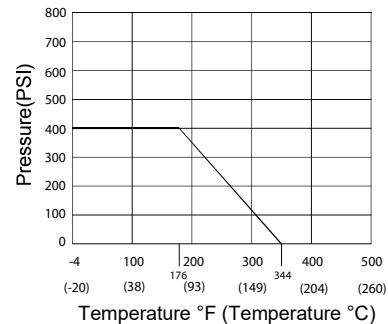

Materials List

NO.	PART NAME	MATERIAL	NO. PCS.
1	BODY	BRASS CW 617 NUNI EN 12165	1
2	END CONNECTION	BRASS CW 617 NUNI EN 12165	3
3	BALL	BRASS CW 617 NUNI EN 12165	1
4	BALL SEAT	PTFE	4
5	THRUST WASHER	PTFE	1
6	STEM SEAL	PTFE	1
7	O-RING STEM	FKM VITON	1
8	O-RING BODY	FKM VITON	4
9	SCREW	STEEL 6/S	1
10	BUSHING WASHER	BRASS CW 614 NUNI EN 12164	1
11	STEM	BRASS CW 614 NUNI EN 12164	1
12	WASHER	NYLON	1
13	HANDLE	FE DD 11 UNI EN 10111	1

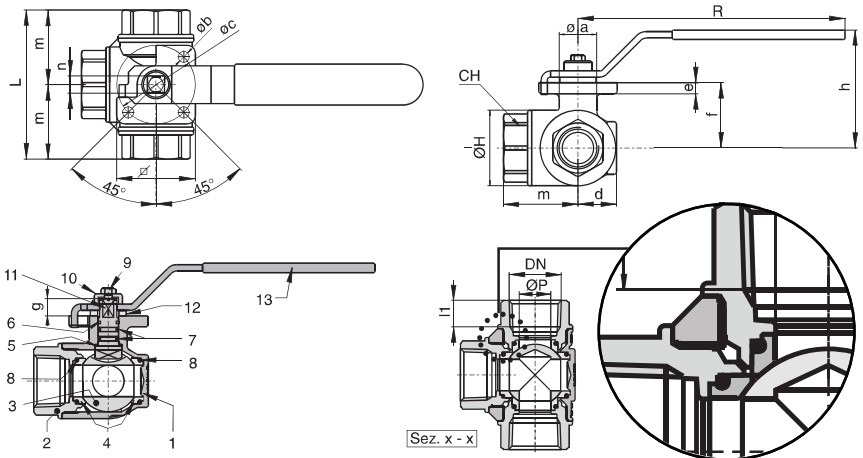

Dimensions (in.)

SIZE	ØP	ØH	l1	L	m	CH	R	h	Øa	Øb	Øc	d	e	f	g	n	Weight (lbs.)	
1/4"	0.39	1.34	0.39	2.64	1.32	0.86	4.72	2.44	0.87	0.23	1.42 (ISO F03)	0.77	0.20	1.20	0.35	1.49	0.35	1.22
3/8"	0.43	1.34	0.40	2.64	1.32	0.86	4.72	2.44	0.87	0.23	1.42 (ISO F03)	0.77	0.20	1.20	0.35	1.49	0.35	1.16
1/2"	0.43	1.34	0.53	2.87	1.44	1.06	4.72	2.44	0.87	0.23	1.42 (ISO F03)	0.77	0.20	1.20	0.35	1.49	0.35	1.21
3/4"	0.59	1.53	0.55	3.19	1.60	1.25	4.72	2.52	0.87	0.23	1.42 (ISO F03)	0.87	0.20	1.29	0.35	1.49	0.35	1.44
1"	0.79	1.89	0.66	3.74	1.87	1.61	6.69	2.95	0.94	0.27	1.97 (ISO F05)	1.00	0.28	1.63	0.43	1.97	0.43	2.64
1-1/4"	0.98	2.36	0.68	4.39	2.20	1.96	6.69	3.17	0.94	0.27	1.97 (ISO F05)	1.22	0.28	1.85	0.43	1.97	0.43	4.15
1-1/2"	1.26	2.83	0.68	4.86	2.43	2.16	6.69	3.66	1.26	0.27	1.97 (ISO F05)	1.79	0.28	2.34	0.43	1.97	0.43	6.02
2"	1.57	3.38	0.70	5.73	2.87	2.75	9.05	4.43	1.46	0.35	2.76 (ISO F07)	1.75	0.32	2.90	0.59	2.75	0.55	9.08
2-1/2"	1.95	4.37	0.93	6.93	3.47	3.34	9.05	4.86	1.46	0.35	2.76 (ISO F07)	2.20	0.32	3.35	0.59	2.75	0.55	16.33
3"	1.95	4.45	1.01	7.08	3.54	4.13	9.05	4.86	1.46	0.35	2.76 (ISO F07)	2.20	0.32	3.35	0.59	2.75	0.55	19.55