

SERIES 920-61

SANITARY 3-PIECE STAINLESS STEEL BALL VALVE
1000 WOG - FULL PORT SANITARY CLAMP ENDS



Specifications:

- ~ Food Grade
- ~ Three Piece
- ~ End Type: Sanitary Clamp Ends
- ~ Pressure rating: 1000 WOG
- ~ Temperature: 0°F to 320°F
- ~ ISO 5211 Top Flange

Materials List

NO.	PART NAME	MATERIAL	NO. PCS.
1	BODY	ASTM-A351-CF8M	1
2	CAP	ASTM-A351-CF8M	2
3	BALL	A351-CF8M	1
4	SEAT	PTFE	2
5	GASKET	PTFE	2
6	STEM	AISI-316	1
7	THRUST WASHER	PTFE	1
8	STEM PACKING	PTFE	1
9	BOLT	AISI-304	4
10	HEX NUT	AISI-304	4
11	BOLT WASHER	AISI-304	4
12	GLAND	AISI-304	1
13	WASHER	AISI-304	1
14	NUT	AISI-304	1
15	HANDLE	AISI-304	1
16	PLASTIC COVER	PLASTIC	1
17	LOCK DEVICE	AISI-304	1
18	STOPPIN	AISI-304	1

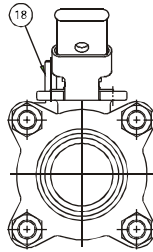

PRESSURE TEMPERATURE RATINGS

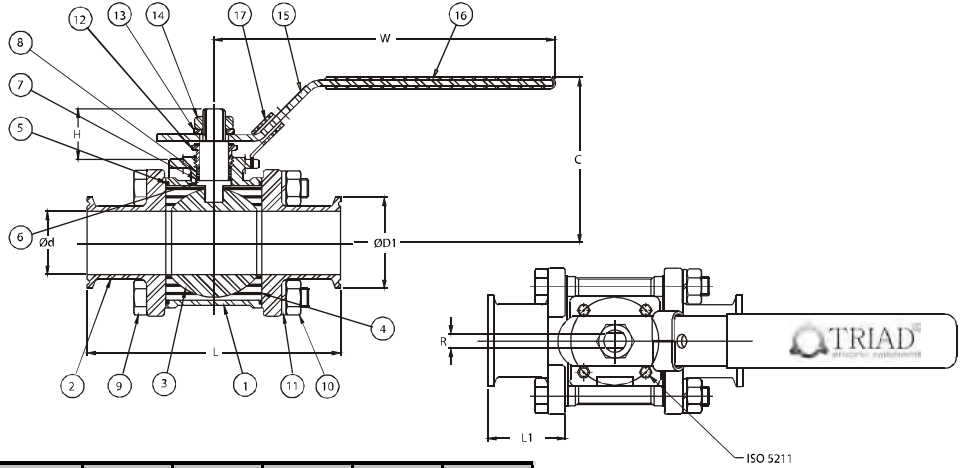
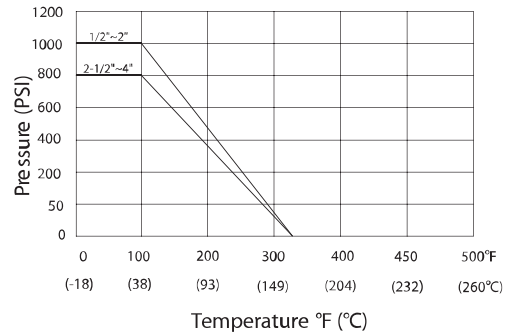

Dimensions (in.)

SIZE	DN	ISO-5211	H	C	R	L	W	Ød	ØD1	L1
1/2"	15	F03	0.71	2.17	0.20	3.50	5.12	0.37	1.00	1.29
3/4"	20	F03	0.73	2.36	0.20	3.98	5.12	0.63	1.00	1.44
1"	25	F04	0.89	2.72	0.26	4.49	6.50	0.87	1.98	1.57
1-1/2"	40	F05	1.17	3.31	0.33	5.51	7.68	1.38	1.98	1.71
2"	50	F05	1.17	3.62	0.33	6.14	7.68	1.87	2.52	1.80
2-1/2"	65	F07	1.75	5.00	0.47	7.76	9.92	2.37	3.05	2.20
3"	80	F07	1.75	5.35	0.47	9.02	9.92	2.87	3.58	2.54
4"	100	F10	1.92	6.26	0.63	9.57	13.07	3.83	4.68	2.39