

TRIAD SERIES HP3W BALL VALVES 3 - WAY HIGH PRESSURE

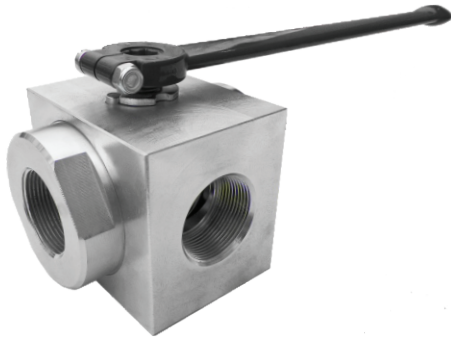

Specifications:

- Diverting L port configuration
- End Type: NPT
- Pressure rating: 5076 PSI
- Temperature: -4°F to 212°F (Carbon Steel)
-76°F to 446°F (Stainless Steel)
- **NPT thread standard**
- **Optional DIN, SAE and BSP threads available**

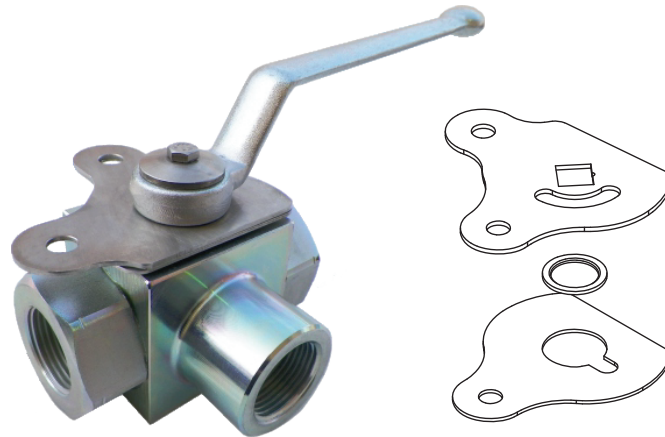

Locking Kits available upon request

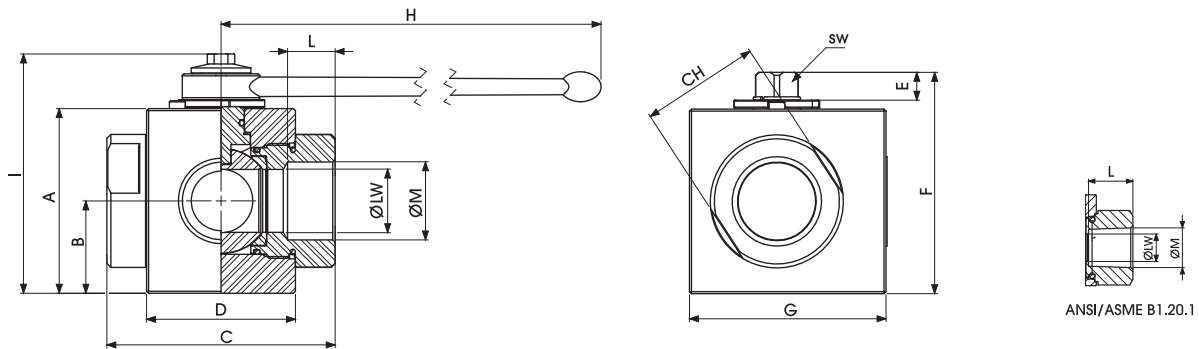

Dimensions

SIZE	A	B	C	D	E	F	G	H	I	L	ØM	CH	SW	ØLW	LBS.
1-1/4"	3.66	1.83	4.53	2.95	0.53	4.39	3.90	11.81	4.74	0.94	1-1/4"	2.36	0.67	1.26	13
1-1/2"	4.21	2.11	5.16	3.35	0.53	4.94	4.53	11.81	5.30	0.98	1-1/2"	2.95	0.67	1.57	19
2"	4.49	2.24	5.51	3.86	0.53	5.22	5.04	11.81	5.57	1.06	2"	3.35	0.67	1.97	23

TRIAD SERIES HP3W BALL VALVES

3 - WAY HIGH PRESSURE

MATERIAL LIST

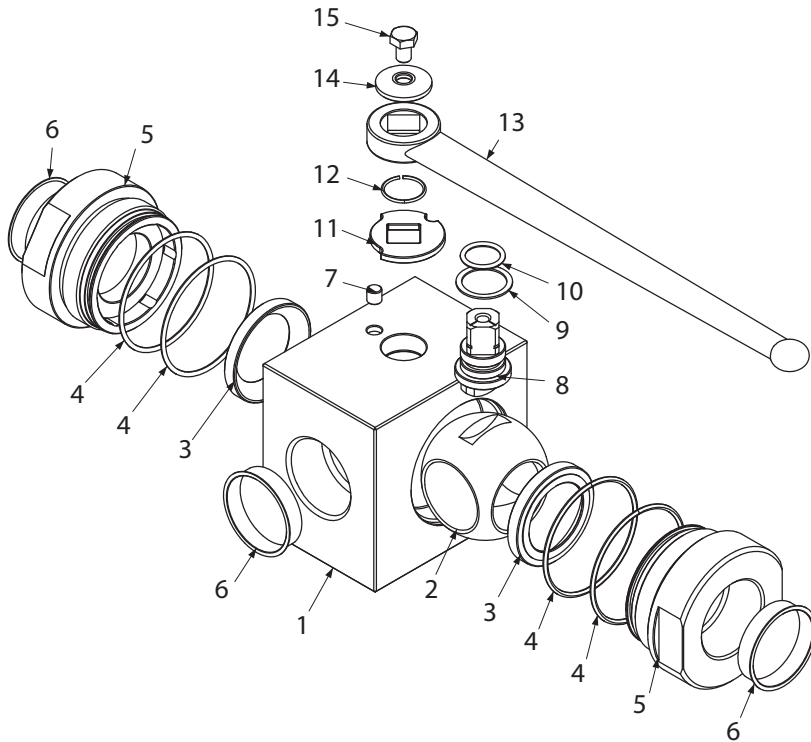
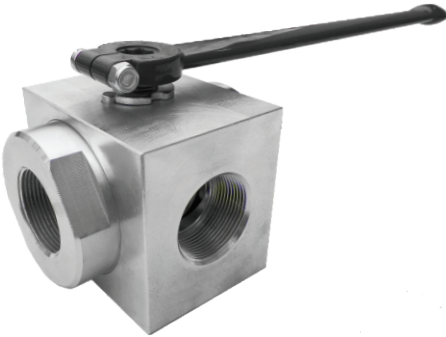

MATERIAL LIST

NO.	PART NAME	MATERIAL		NO. PCS.
		CS	SS	
1	BODY	CS	SS	1
2	BALL	CS	SS	1
3	BALL SEAT	POM		2
4	ADAPTER O-RING	NBR		4
5	ADAPTER	CS	SS	2
6	CAPS	PVC		3
7	STOP	CS	SS	1
8	STEM	CS	SS	1
9	STEM RING	POM		1
10	STEM O-RING	NBR		1
11	WASHER	CS	SS	1
12	SNAP RING	SS		1
13	HANDLE	CS	SS	1
14	WASHER	CS	SS	1
15	SCREW	ISO 4017 8.8		1

PRESSURE TEMPERATURE RATINGS

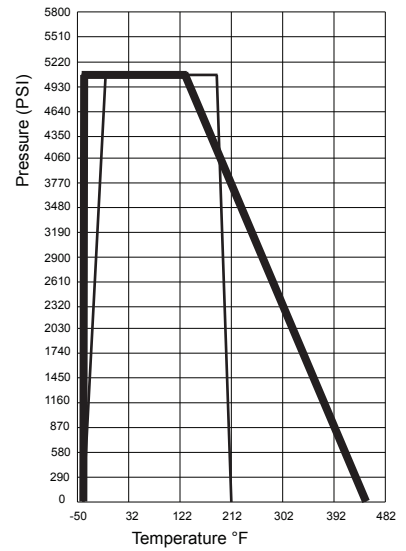

 Stainless Steel
 Carbon Steel