

# SERIES 40X-92061

4-WAY SANITARY DIRECT MOUNT BALL VALVE  
FULL PORT - 800 WOG - SANITARY ENDS

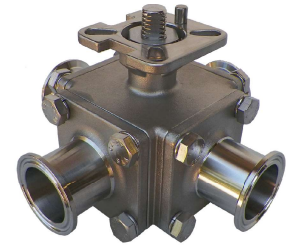

### Specifications:

- Four Piece
- Four way
- End Type: Sanitary Clamp Ends
- Pressure rating: 800 WOG
- Temperature: -20°F to 400°F
- Blow-out proof stem design
- ISO 5211 Top Flange for Direct Mounting

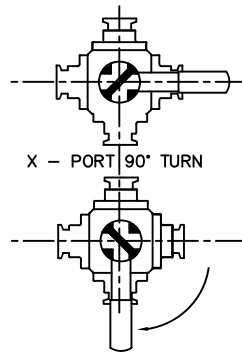

PRESSURE TEMPERATURE RATINGS

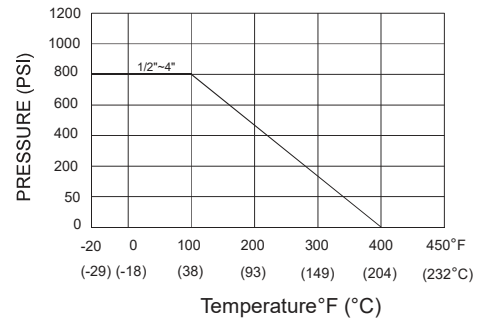

### Materials List

NO	PART NAME	MATERIAL	NO. PCS.
1	BODY	A351 Gr. CF8M	1
2	T-CLAMP CAP	A351 Gr. CF8M	3
3	CAVITY FILL SEAT	PTFE	2
4	GASKET	PTFE	4
5	BLANK CAP	A351 Gr. CF8M	1
6	BALL SEAT	PTFE	4
7	PIN	SS 316	1
8	STEM	SS 316	1
9	THRUST WASHER	PTFE	1
10	O-RING	VITON	1
11	STEM PACKING	PTFE	1
12	GLAND	SS 304	1
13	DISC WASHER	SS 301	2
14	STEM NUT	SS 304	1
15	NUT STOP	SS 304	1
16	SPACE	SS 304	1
17	PLATER STOP	SS 304	1
18	HANDLE NUT	SS 304	1
19	HANDLE	SS 304	1
20	HANDLE SLEEVE	VINYL	1
21	STOP PIN	SS 304	1
22	STOP PIN NUT	SS 304	1
23	END CAP BOLTS	B8	16
24	CAVITY FILL HOUSING	PTFE	2

### Cavity Filler Detail

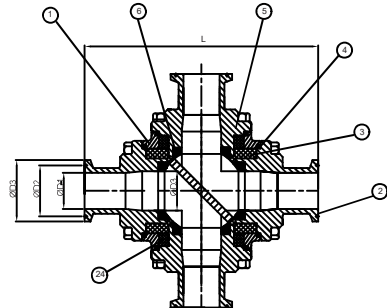
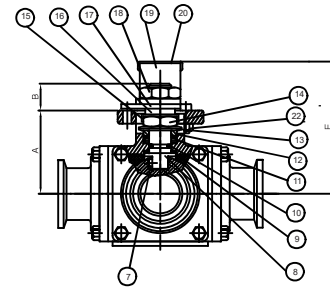
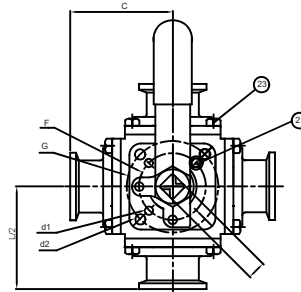

### Dimensions (in.)

SIZE	A	B	C	d1	d2	E	F	G	H	L/2	L	D	D1	D2	D3	ISO5211
1/2"	1.52	0.43	5.12	0.24	0.24	2.44	1.42	1.65	0.35	2.36	4.72	0.47	0.38	0.85	0.98	F03/F04
3/4"	1.61	0.43	5.12	0.24	0.24	2.52	1.42	1.65	0.35	2.68	5.35	0.59	0.62	0.85	0.98	F03/F04
1"	2.17	0.55	6.50	0.24	0.28	3.50	1.65	1.97	0.43	3.15	6.30	0.98	0.87	1.71	1.98	F04/F05
1-1/2"	2.91	0.71	8.07	0.28	0.36	4.25	1.97	2.76	0.55	3.58	7.17	1.50	1.37	1.71	1.98	F05/F07
2"	3.66	0.91	12.80	0.36	0.45	5.51	2.76	4.02	0.67	4.25	8.50	1.97	1.87	2.22	2.52	F07/F10

**Specifications:**

- Four Piece
- Four way
- End Type: Sanitary Clamp Ends
- Pressure rating: 800 WOG
- Temperature: -20°F to 400°F
- Blow-out proof stem design
- ISO 5211 Top Flange for Direct Mounting

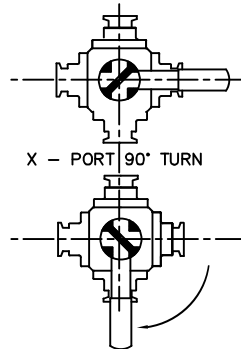
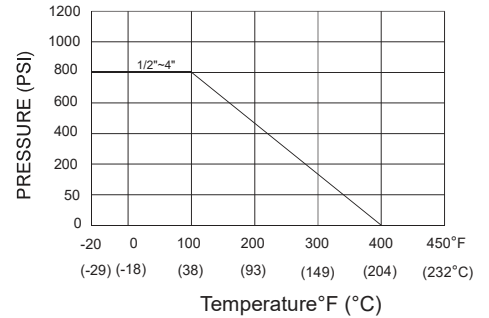
**PRESSURE TEMPERATURE RATINGS**

**Materials List**

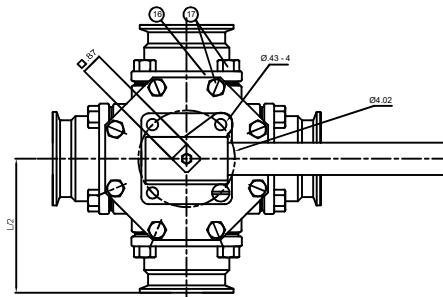
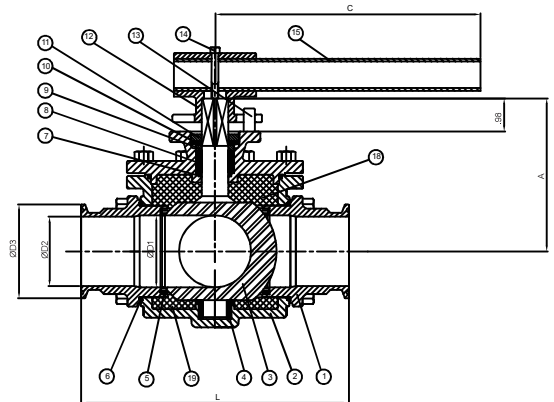
NO	PART NAME	MATERIAL	NO. PCS.
1	T-CLAMP CAP	A351 Gr. CF8M	1
2	BODY	A351 Gr. CF8M	3
3	BALL & STEM	SS 316	2
4	HOUSING	RPTFE + STAINLESS	4
5	SEATS	PTFE	1
6	GASKET	PTFE	4
7	O-RING	VITON	1
8	STEM PACKING	PTFE	1
9	GLAND WASHER	SS 304	1
10	DISC WASHER	SS 301	1
11	GLAND	SS 304	1
12	HANDLE HEAD	A351 Gr. CF8M	1
13	STOP PIN	SS 304	2
14	BOLT	SS 304	1
15	LEVER	CARBON STEEL	1
16	BLANK END	A351 Gr. CF8M	1
17	CONNECTION BOLTS	SS 304	1
18	CAVITY FILLER (A)	PTFE	1
19	CAVITY FILLER (B)	PTFE	1

**Cavity Filler Detail**

**Dimensions (in.)**

SIZE	A	C	D1	D2	D3	L	L/2	ISO5211
2-1/2"	5.67	15.75	2.44	2.37	3.05	9.50	4.75	F10
3"	6.38	19.69	2.99	2.87	3.58	11.00	5.50	F10
4"	7.17	25.59	3.78	3.83	4.69	13.00	6.50	F10